



www.geoplast.it

GEOSKY®

GEOSKY® Plastic formwork system for advanced slab dismantling

GEOSKY® is a system of plastic formwork used to pour concrete slabs. Thanks to its combination of main beam and sliding wedge, this innovative system makes setup and dismantling faster, and reduces the turn-around time of the equipment. It is composed by Geopanel® 120x60 cm panels (weighing 11 kg each) and by 3 plastic beams to place upon the traditional H20 wooden truss. This system allows to advance the partial dismantling operation to one single day from the pour. GEOSKY® is the ideal solution to pour any kind of slab: bidirectional, full or lightened.

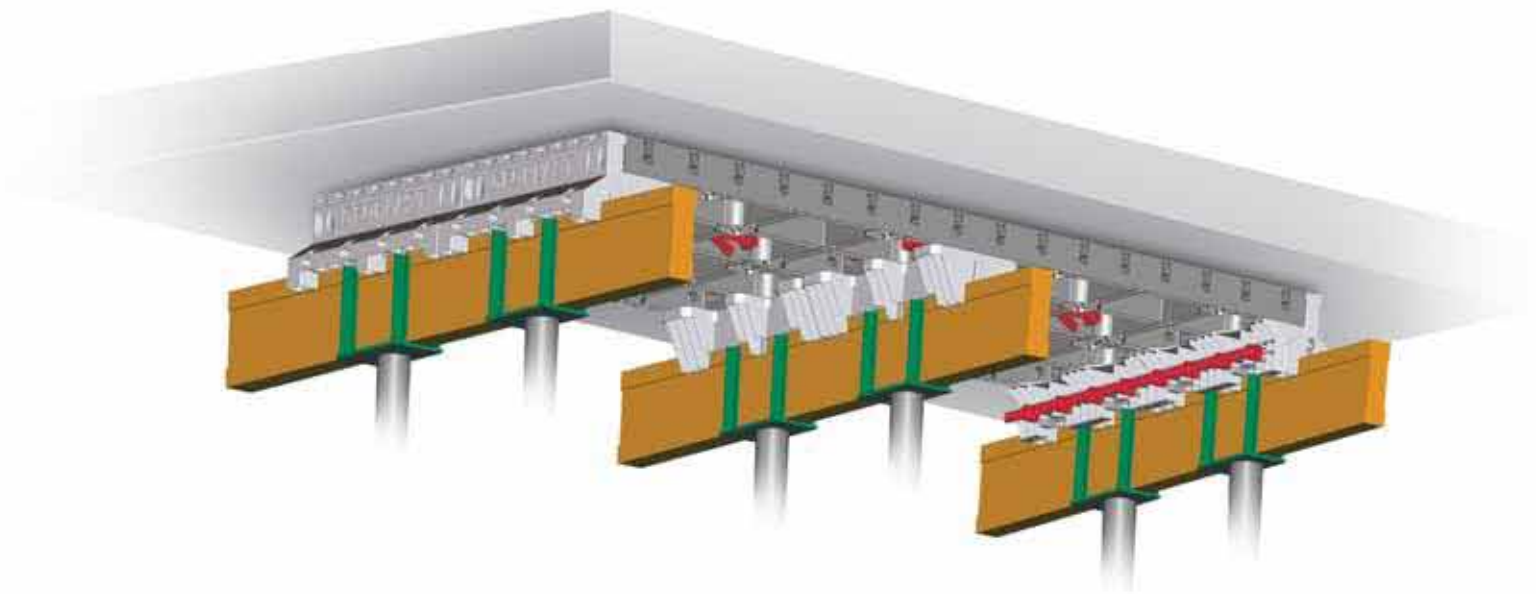

Supplied by



RIGHT PRODUCT
RIGHT PRICE
RIGHT TO YOUR SITE



09 42 68 101

sales@everitts.co.nz

www.everitts.co.nz

GEOSKY® ADVANTAGES



TECNOLOGY

GEOSKY® is an innovative system that has the excellent resistance and lightness of plastic and fulfills the requirements of the building industry.

ADVANCED DISMANTLING

GEOSKY® makes partial dismantling of the panels possible after just one day (depending from the slab type, the concrete grade used and the season). Advanced dismantling is possible thanks to the sliding wedge system.

FAST SET-UP

The simple mechanical device of **GEOSKY®** speeds up the assembling and stripping operations thanks to the lightness of each element. This is the reason why time is saved compared to traditional formwork systems.

FLEXIBILITY

No special panels are needed with **GEOSKY®** as it uses the same panels (Geopanel) employed to make walls.

SAFETY

Thanks to the access from below, **GEOSKY®** allows safer working conditions avoiding fall hazard during both setup and dismantling.

EASY HANDLING

Each **GEOSKY®** element is made of plastic: the maximum weight is 11 kg and one person can set-up the product by himself.

SIMPLIFIED LOGISTICS

GEOSKY® reduces the amount of material needed at the construction site.

APPLICATION FIELDS

GEOSKY® is suitable for the construction of slabs in multy-storey car parks, commercial-, industrial- and residential buildings.

EASY CLEANSING

As concrete does not stick to plastic, dismantling is easy and cleansing simple: just use water, without any need for specific detergents.



GEOSKY® COMPONENTS

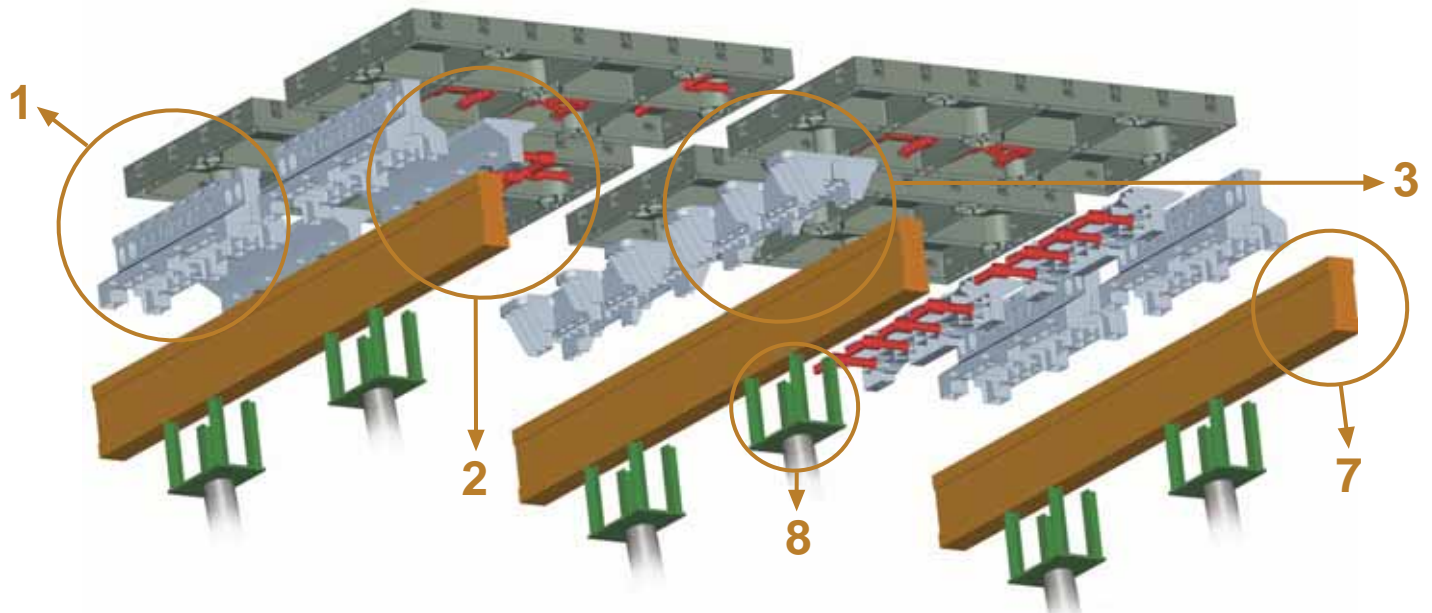

1

Y-BEAM L 60 cm
(act. size L 60.5 cm) MATERIAL: ABS . WEIGHT 2.97 kg

It lodges onto standard H20 timber beams. The wedge is joined by the simple 90 degree rotation of the handles.

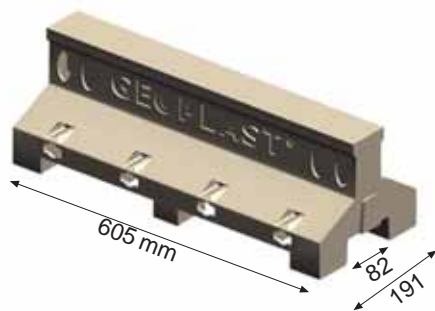

2

WEDGE L 60 cm
(act. size L 60.5 cm) MATERIAL: ABS . WEIGHT: 1.90 kg

This element allows the advanced dismantling of the slab formwork: detaching the wedge from the Y-beam, the panel can be freely removed from under the concrete slab.

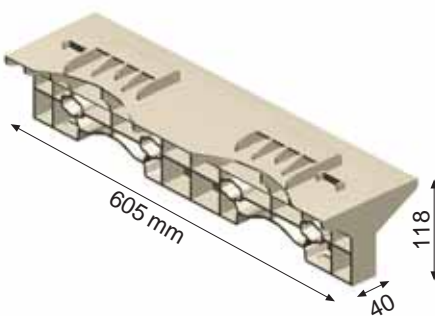

3

H-BEAM . L 60 cm
(act. size L 60.5 cm) MATERIAL: ABS . WEIGHT 3.00 kg

This element acts as the crosspiece and is among the first elements to be removed during dismantling, together with its wood beam and the posts.

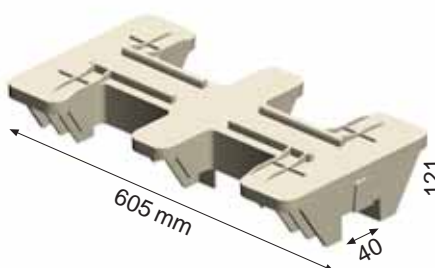

4

GEOPANEL® . ELEMENT 120 X H 60 cm
(act. size 121 x 60.5 cm)
MATERIAL: ABS WEIGHT: 11 kg

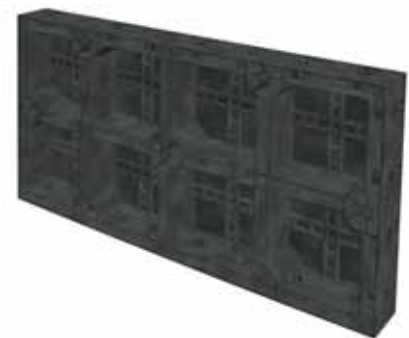

5

HANDLE
MATERIAL: Nylon
WEIGHT: 0.101 kg



6

CAP for spacers
MATERIAL: HD PE
WEIGHT: 0.006 kg



7

H20 BEAM with end reinforcement
MATERIAL: wood



8

FORKHEAD
MATERIAL: Steel



9

PROP high load bearing capacity
MATERIAL: Steel



GEOSKY® SETUP AND DISMANTLING

GEOSKY® SETUP



1 Place pre-assembled Y-beam and wedges



2 Place the H-beam



3 Place the GEOPANEL® 120 panel



4 Block the panels onto the Y-beams



5 Fully assembled GEOSKY®

GEOSKY® PARTIAL ADVANCED DISMANTLING



1 Remove the H-beams

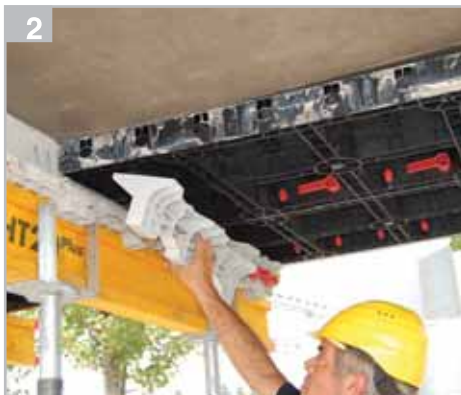

2 Remove the wedges



3 Remove the panels



4 Final result

GEOSKY® SETUP AND DISMANTLING

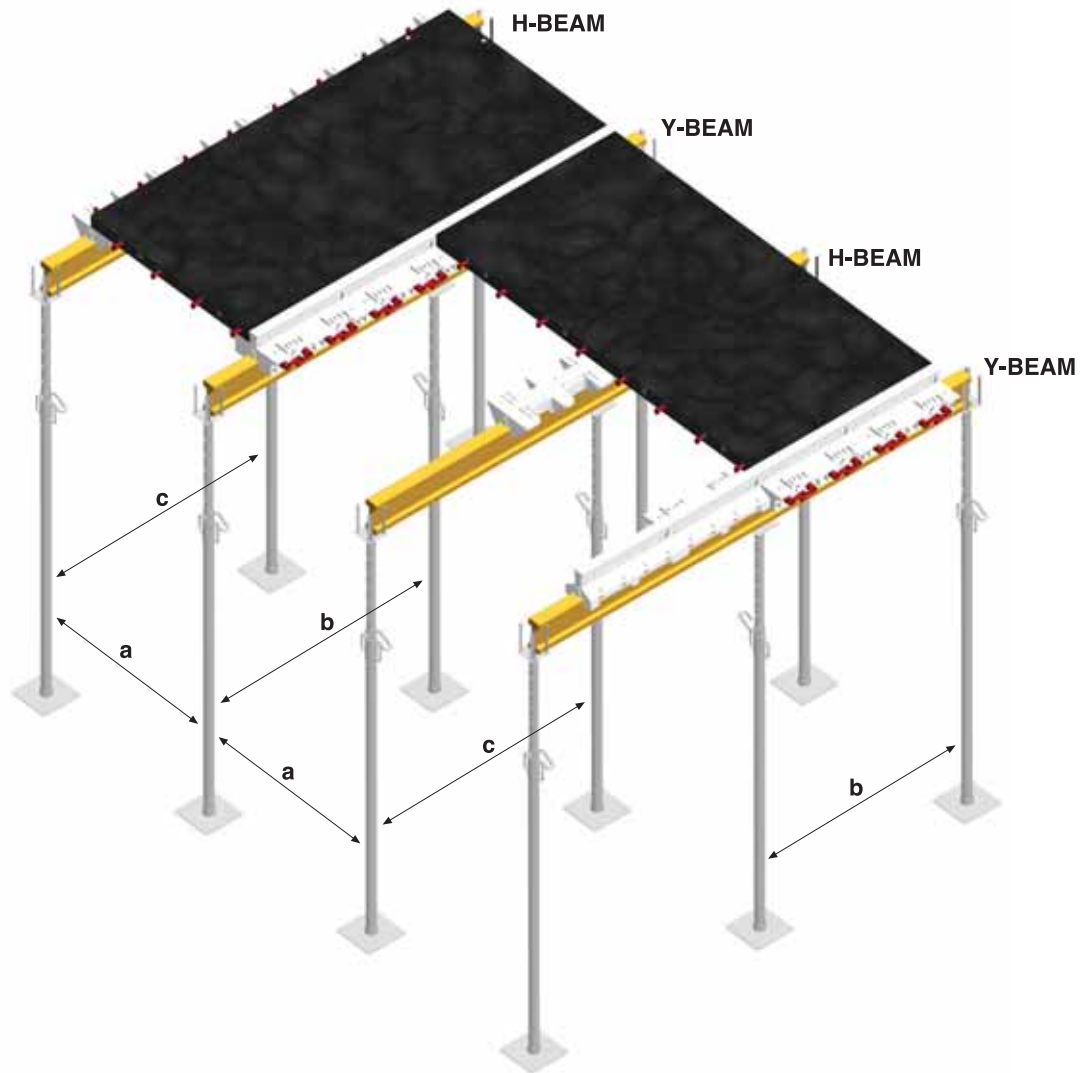

THICKNESS OF THE REINFORCED CONCRETE SLAB (cm)

		15	20	20	25	30	35	40
a	Spacing of the beams [a] (cm)	124	124	124	124	63.5	63.5	63.5
b	Spacing of the Y-beam props [b] (cm)	150	150	100	100	150	150	100
c	Spacing of the H-beam props [c] (cm)	150	150	150	150	150	150	150
	Maximum overload per prop	16 kN 1,600 kg	20 kN 2,000 kg	14 kN 1,400 kg	17 kN 1,700 kg	16 kN 1,600 kg	18 kN 1,800 kg	14 kN 1,400 kg

DISMANTLING

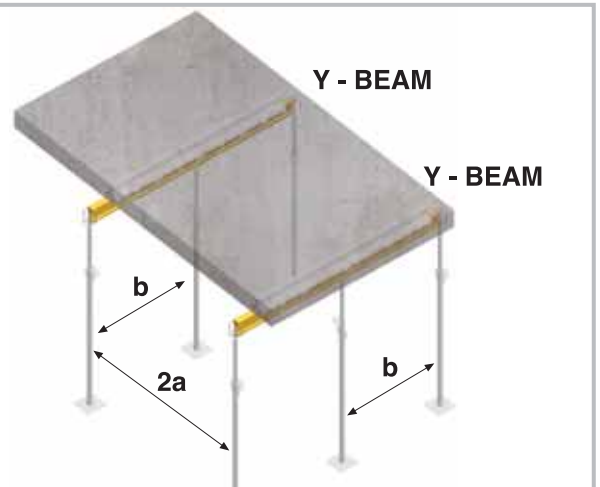

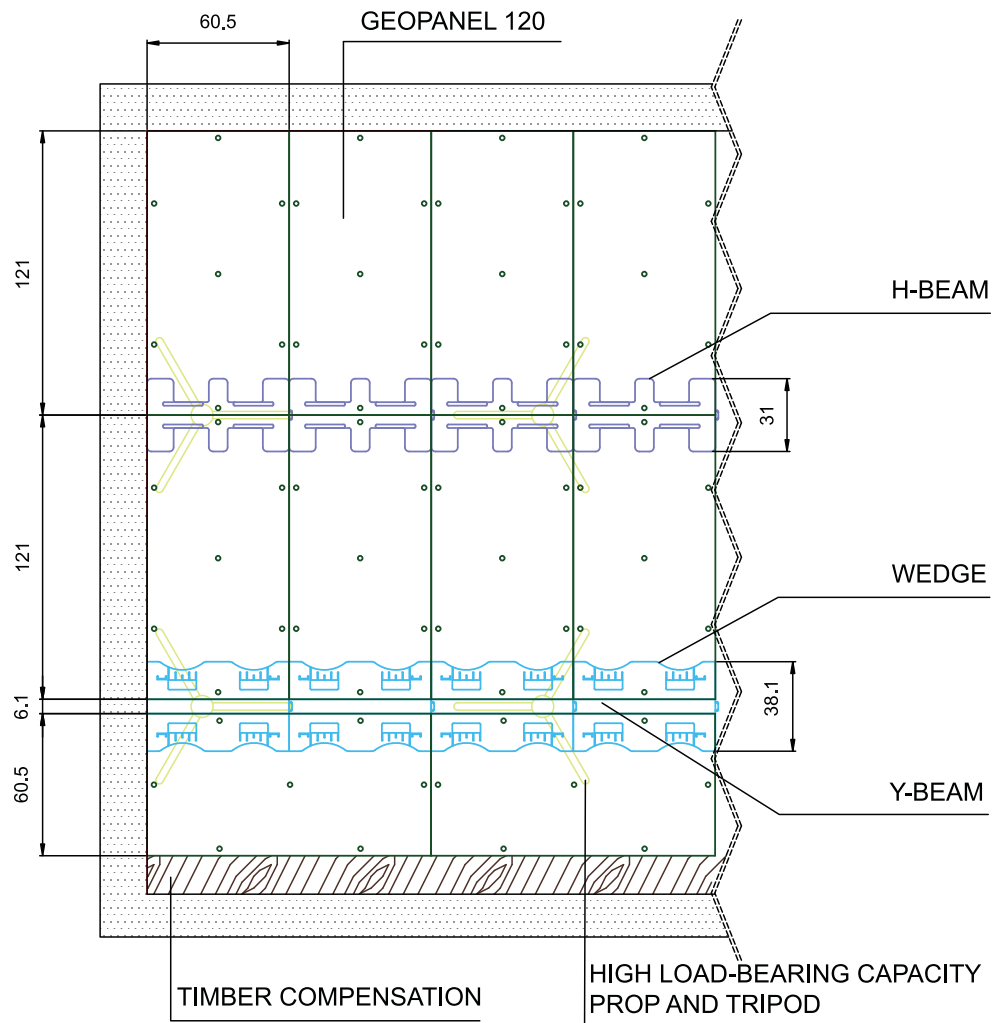

*All dimensions are expressed in cm.

The panels of the **GEOSKY®** system can be placed with at centres 120 cm or 60 cm. Close to perimetral walls, columns, elevator shafts, etc. compensation is required with Geopanel 25, 30 or 40 cm, or timber for other gaps.



1

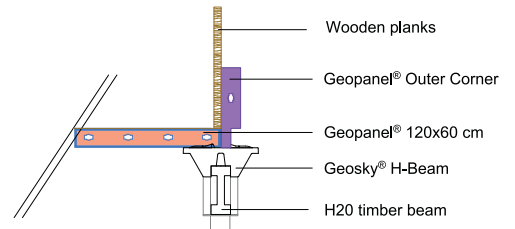
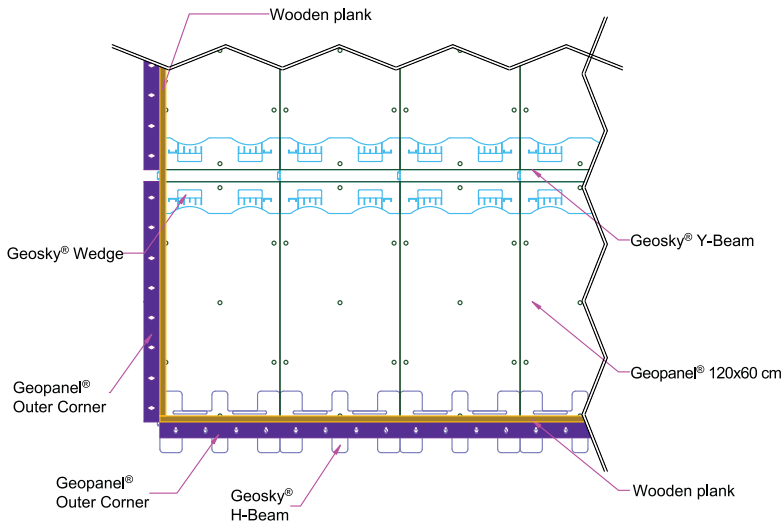

High load-bearing capacity props



Solution for the closure of a slab with GEOPANEL® outer corner and timber

2

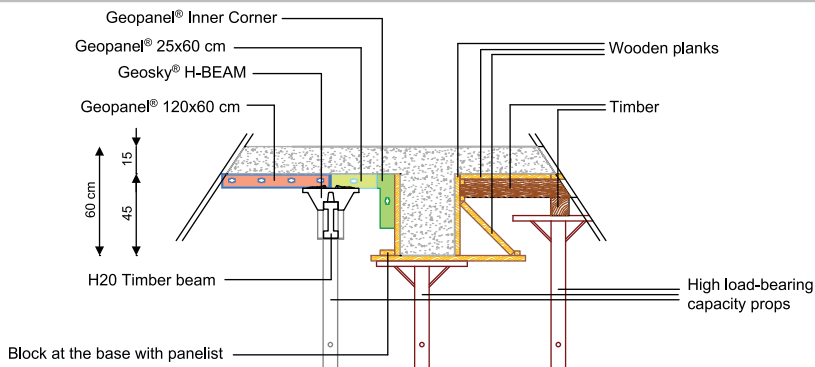

Solution for monolithic slab and beams

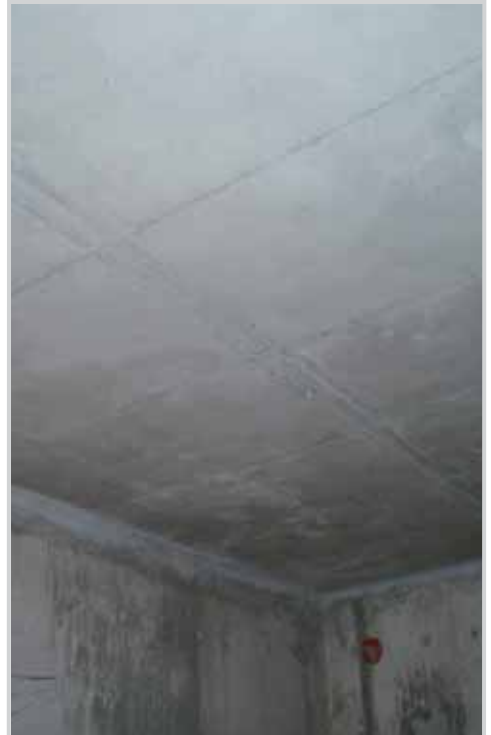

GEOSKY® PLASTIC FORMWORK SYSTEM FOR ADVANCED SLAB DISMANTLING



CUSTOMER SERVICE PROJECT DEVELOPMENT

Send your projects in DWG format to ufficiotecnico@geoplast.it

ASSEMBLY HANDBOOK AND TECHNICAL SPECIFICATIONS

Available in our website www.geoplast.it in the "Documents and data" section

REV.1 20/03/08 www.librecoira.com

Supplied by



RIGHT PRODUCT
RIGHT PRICE
RIGHT TO YOUR SITE



09 42 68 101 sales@everitts.co.nz www.everitts.co.nz